

特性 / FEATURES

- 30A触点切换能力
30A switching capability
- 一组常开、一组常闭触点形式
1 Form A and 1 Form B type available
- 安装方式: 金属柄
Mounting Form : metal bracket



RoHS
Compliant

订购信息 / ORDERING INFORMATION

SLND-12-R-A

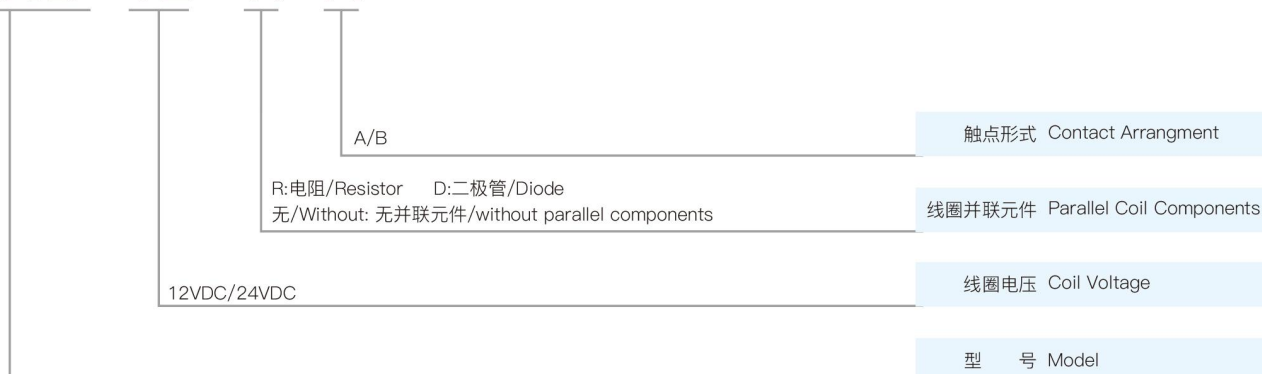

触点参数 / CONTACT PARAMETERS

触点形式	Contact arrangement	A/B
接触压降(10A下测量)	Voltage drop (at 10A)	≤200mV
触点材质	Contact material	银合金/Silver alloy: AgSnO ₂ In ₂ O ₃ 、AgSnO ₂ 、AgNi
触点负载	Contact rating	30A 14VDC
最大切换电压	Max switching voltage	50VDC
最大切换电流	Max switching current	35A (阻性/Resistive 14VDC)
最小负载	Min contact load	1A 6VDC
电耐久性 (频率:每小时900次)	Electrical endurance (Frequency:900 ops/h)	1×10 ⁵ ops
机械耐久性 (频率:每小时18000次)	Mechanical endurance (Frequency:18000 ops/h)	1×10 ⁷ ops

汽车继电器 Automotive Relay

30A

特性参数 / CHARACTERISTICS PARAMETERS

绝缘等级	Insulation level	Class B / Class F	
绝缘电阻	Insulation resistance	100MΩ (500VDC)	
介质耐压 (漏电流 1mA)	Dielectric strength (Leakage current 1mA)	线圈与触点间耐压 Dielectric strength (Between coil and contacts)	500VAC 1分钟/minute
		断开触点间耐压 Dielectric strength (Between open contacts)	500VAC 1分钟/minute
吸合时间(额定电压下)	Operate time(at nominal voltage)	≤10ms	
释放时间(额定电压下)	Release time (without diode)(at nominal voltage)	≤10ms	
湿度	Humidity	5% ~ 85% RH	
环境温度	Ambient temperature	-40°C ~ +125°C	
抗振动	Vibration resistance	5Hz~22.3Hz 10mm 双振幅/Double amplitude	
		22.3Hz~500Hz 98m/s ²	
抗冲击	Shock resistance	294m/s ²	
重量	Weight	约/Approx 31.5g	
封装形式	Construction	防尘型/Dustproof	

备注: 以上数据均为初始值

Remark: All above data is initial value

线圈参数 / COIL PARAMETERS

常温/At 23°C

功耗(W)	Power consumption(W)	1.5W	1.7W	1.5W	1.7W
额定电压(VDC)	Nominal voltage(VDC)	12	12	24	24
线圈电阻(Ω±10%)	Coil resistance(Ω±10%)	96	96	384	384
并联电阻(Ω)	Parallel resistance(Ω)		680		2700
吸合电压(Max)	Pick-up voltage(Max)	65%额定电压(Nominal voltage)			
释放电压(Min)	Drop-out voltage(Min)	10%额定电压(Nominal voltage)			
允许最大电压(VDC)	Max allowable overdrive voltage(VDC)	150%额定电压(Nominal voltage)			

线路图(顶视图) / WIRING DIAGRAM (TOP VIEW)

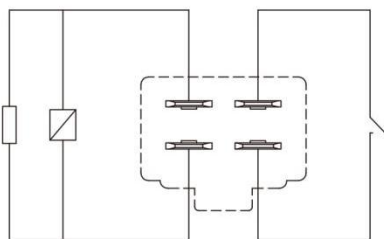

常开A型/Normally open A type

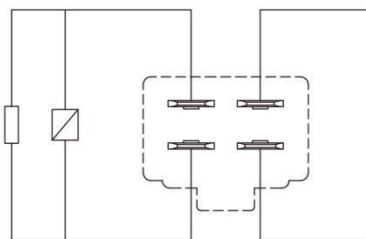

常闭B型/Normally closed B type

外形图 / OUTLINE DIMENSIONS

单位/Unit(mm)

SLND-12(24)-R-A(B)

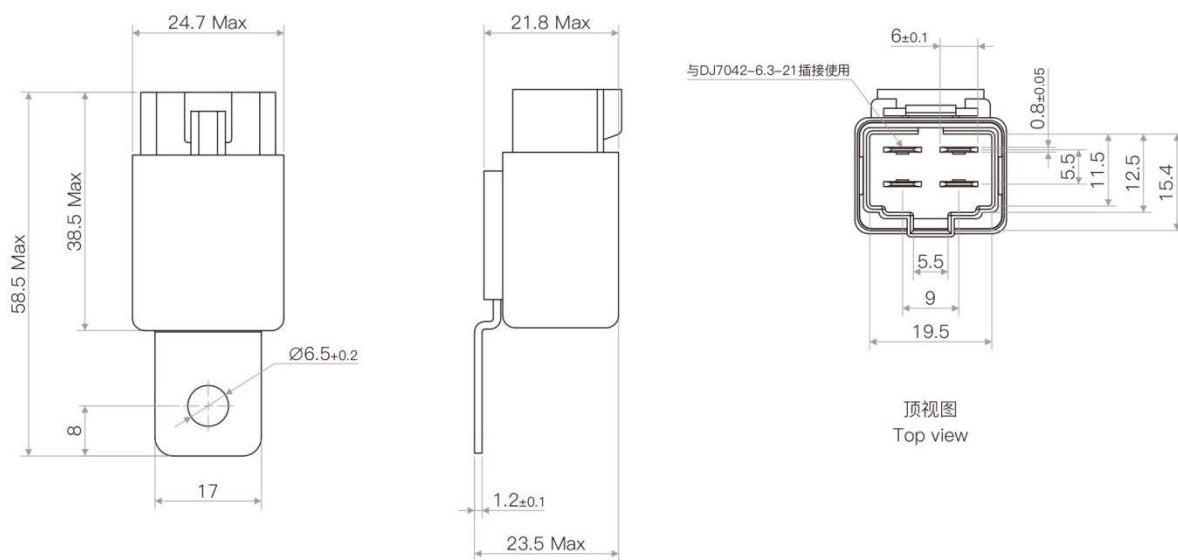

未注公差/Tolerance:±0.3

端子垂直度/Terminal vertical deviation tolerance:0.3mm

性能曲线图 / CHARACTERISTIC CURVES

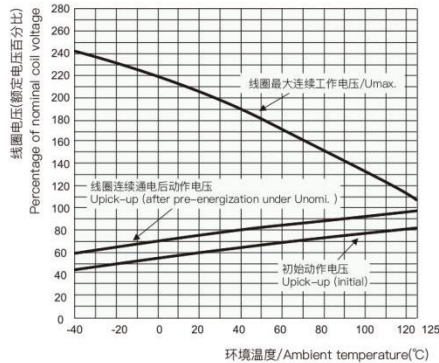

线圈连续通电电压范围

Coil operating voltage range

- (1) 动作电压与线圈预通电时间、预通电电压有关，在预通电后检测动作电压，其值会变大。
- (2) 线圈最大允许温度为 180°C ，考虑到电阻法所测量的线圈温升是平均值，推荐在不同使用环境、不同线圈电压、不同负载条件下测量时，线圈温度应小于 170°C 。
- (3) 当线圈实际工作电压超出曲线规定范围时，请联系松乐并提供详细使用条件。

- (1) The operating voltage is connected with coil energized time and voltage. After energized, the operating voltage will increase.
- (2) The maximum allowable coil temperature is 180°C . Considering the coil temperature rise which is measured by resistance is average value, we recommend the coil temperature should be below 170°C under the different application ambient, different coil voltage and different load etc.
- (3) If the actual operating coil voltage is out of the specified range, please contact Songle for further details.

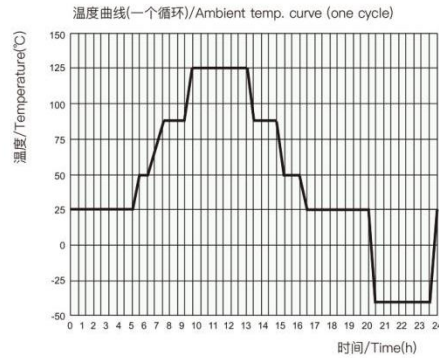

电耐久性试验环境温度曲线

Ambient temperature curve of the electrical endurance test

- (1) 最低温度为 -40°C 。
- (2) 最高温度为 125°C 。

- (1) The minimum temperature is -40°C .
- (2) The maximum temperature is 125°C .